

Appendix A

PAF-937M Interface

This appendix describes PAF-937M Interface.

The separation system, PAF-937M, features a Marman clamp band with a diameter of 937 mm and a low shock separation mechanism (LSSM) with a non-pyrotechnic device.

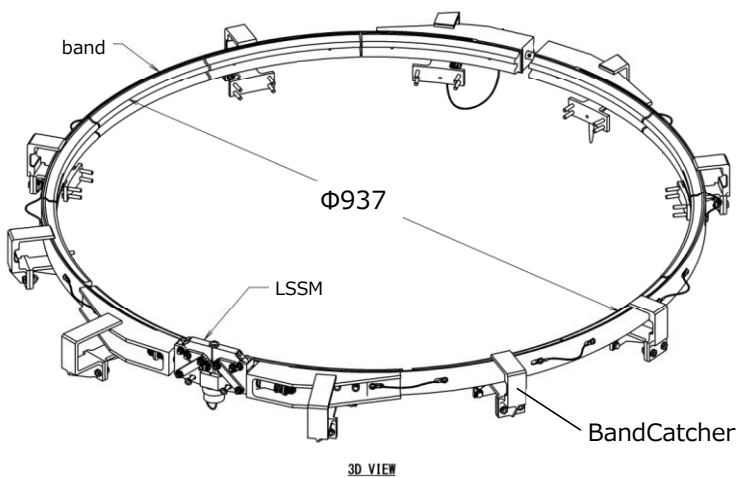

Marman Clamp Band of PAF-937M

A1. Details of Mounting Position

Distances from STA* to the separation plane are as follows:

- For single launch STA 6698.5 mm
- For multi launch STA 5238.5 mm

*STA (station): The origin is at the top of the fairing, from which distances are measured in a longitudinal direction of LV, or along X_B axis. The figure increases toward lower stages.

The coordinate system in this document is the same as shown in Chapter 2.2. The origin is at the center of the separation plane.

A2. PL Usable Volume

PL usable volume is defined in Chapter 4.1.1.

The usable volume for PL in single launch is shown in Figure 4-1.

The usable volume for Small satellite in multi launch is shown in Figure A2-1.

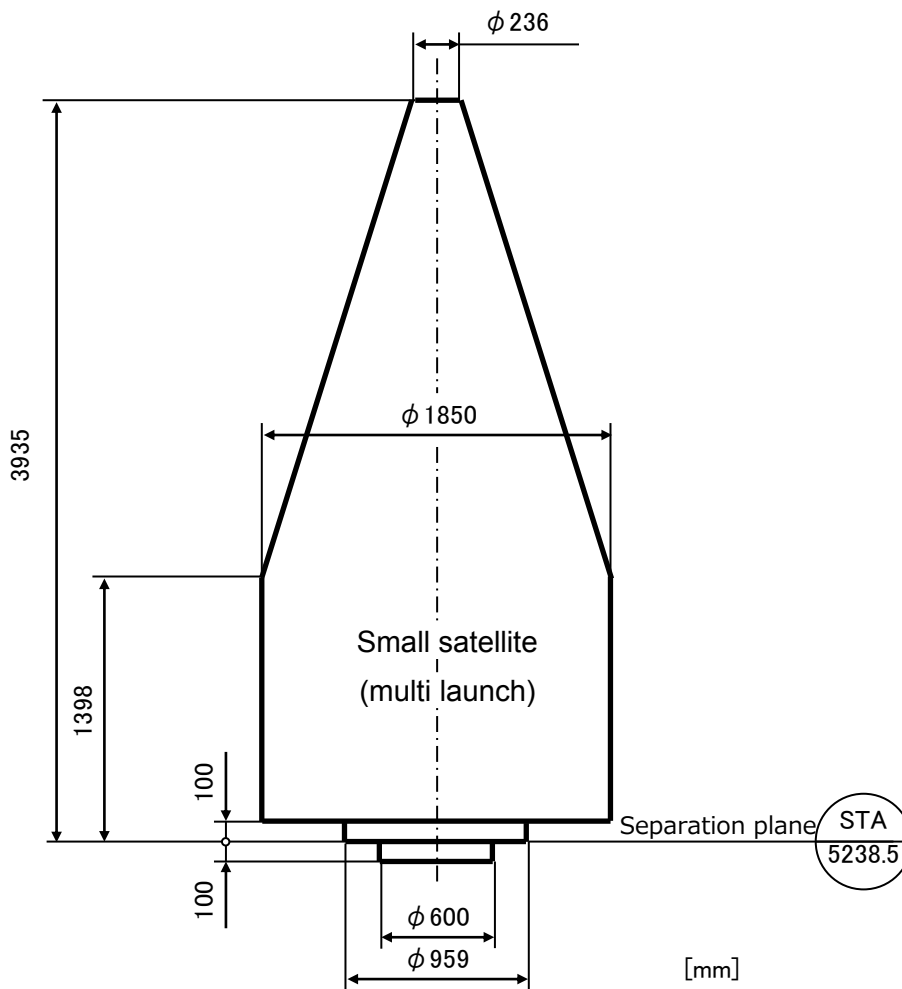

Figure A2-1 PL Usable Volume (multi launch)

A3. Mechanical Interface

(1) Configuration of PAF (LV side)

The separation mechanism of PAF-937M is shown in Table A3-1.

The cross section of the separation flange is shown in Figure A3-1.

The locations of separation springs, separation switches and separation connectors are shown in Figure A3-2.

Table A3-1 Separation Mechanism of PAF-937M

Separation Method	Separation Spring
Clamp	Marman Clamp band
Others	Separation Switch (micro switch)
	Separation Connector
	Band Catcher

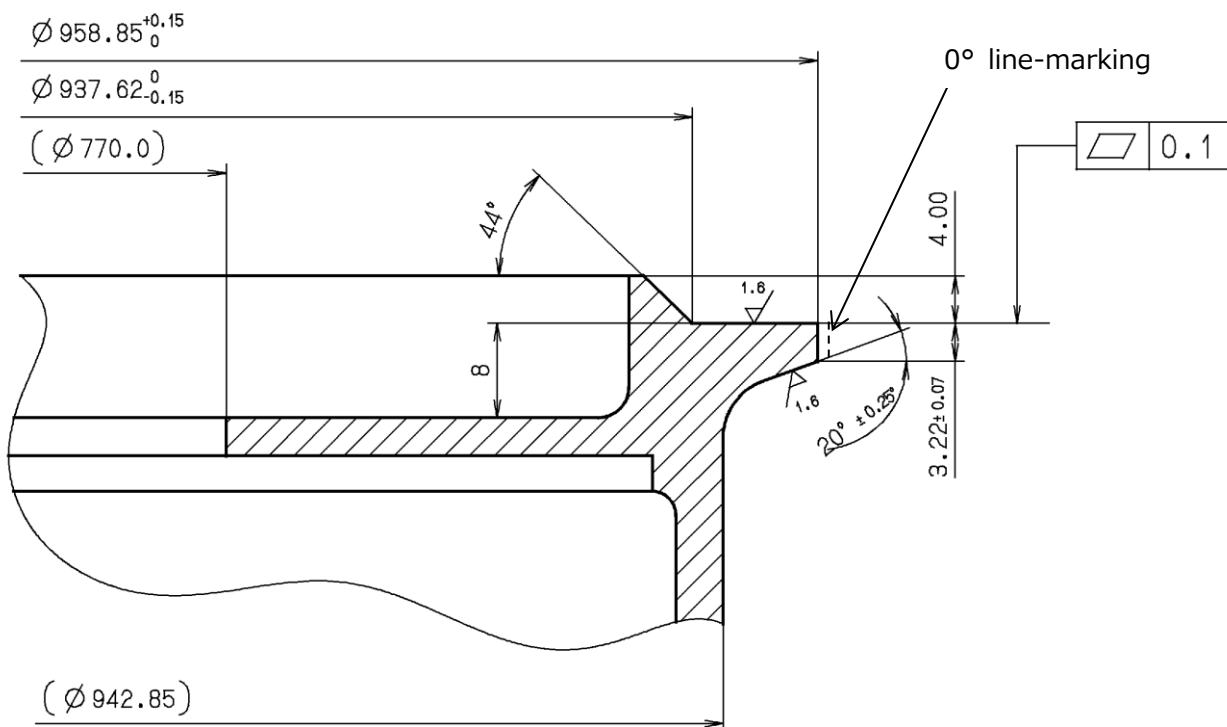

Figure A3-1 Cross Section of Separation Flange around Separation Plane

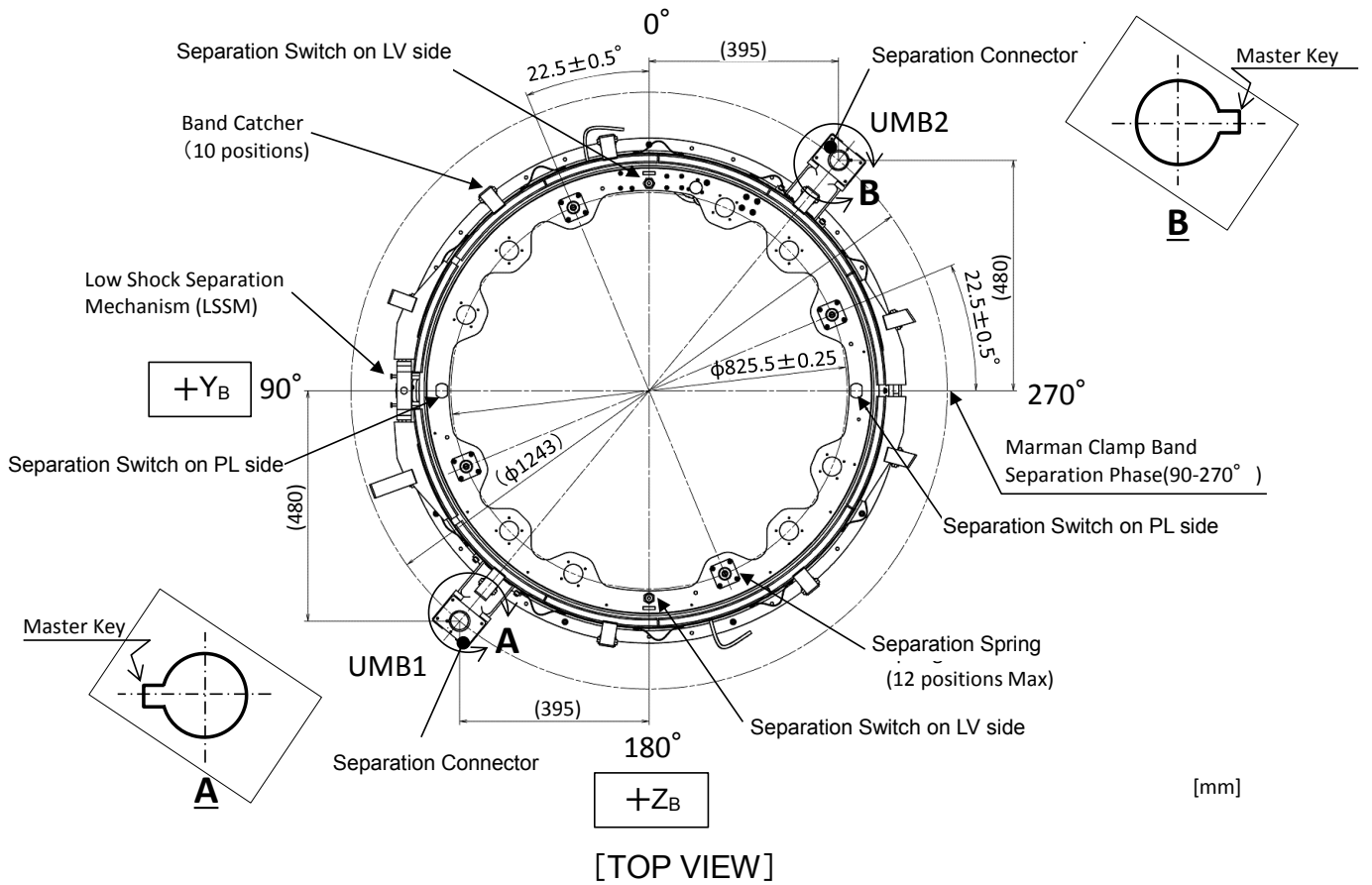

Figure A3-2 Locations of Separation Springs, Separation Switches and Separation Connectors on Separation Flange (LV side)

(2) PL's Rear Frame

The load applied to PL's rear flange by a separation spring during PL/LV mating dose not exceed 1,400 N.

PL's rear frame shall satisfy the following requirements.

- Material : Aluminum alloy
- Area : $A \geq 347.3$ [mm²]
- Moment of inertia of area : $I_{zz} \geq 16130.1$ [mm⁴], $I_{yy} \geq 12365.2$ [mm⁴]
- Length : $L = 25$ [mm]

PL's rear frame and PAF's separation flange are joined by a Marman clamp band. Its typical specifications are as follows:

- Tension : 18 [kN] or less
(temporarily rises up to 35 kN during clamping work.)
- Phase of Separation Mechanism Location: 90° (in LV coordinate system)

The details of PL's rear frame are described in ICD.

The typical examples are shown as follows:

- Cross section of PL's rear frame around the separation plane : Figure A3-3
- Contact surface with an LV separation spring : Figure A3-4

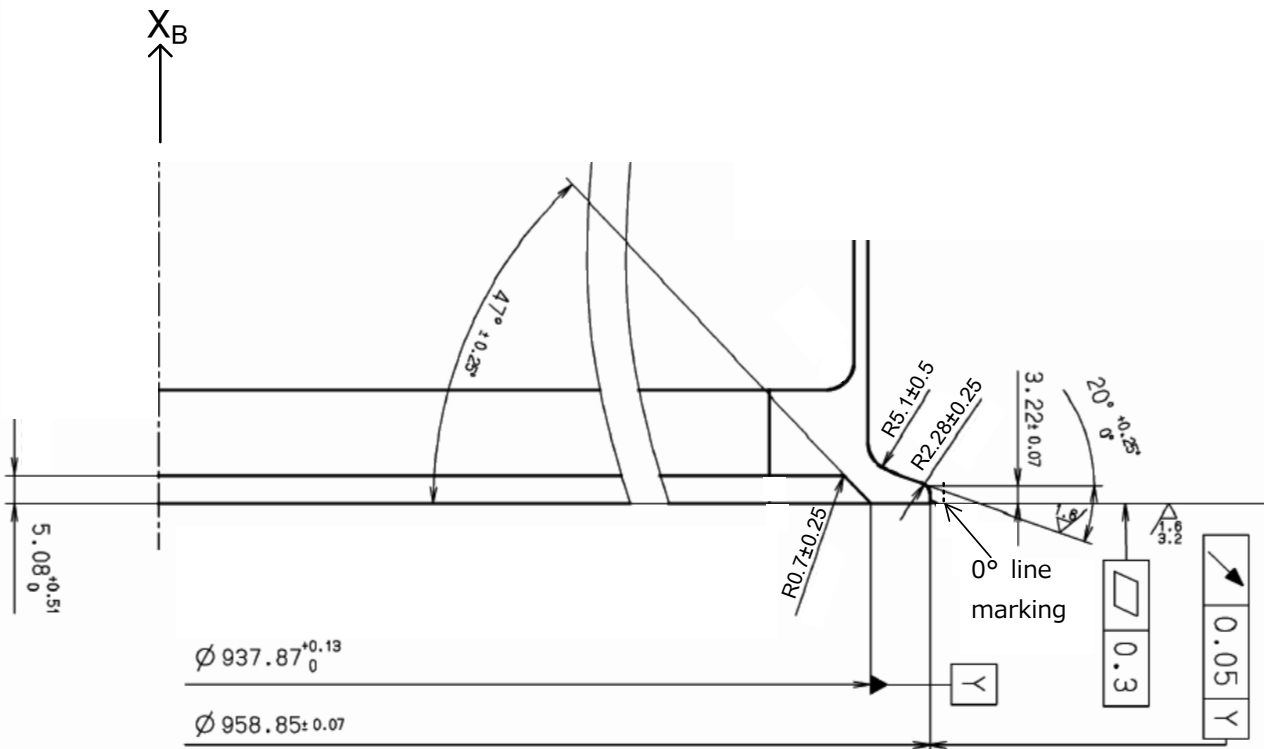

*X_B: the longitudinal axis of LV body (See Chapter 2.2)

Figure A3-3 Typical Cross Section of PL's Rear Frame around Separation Plane

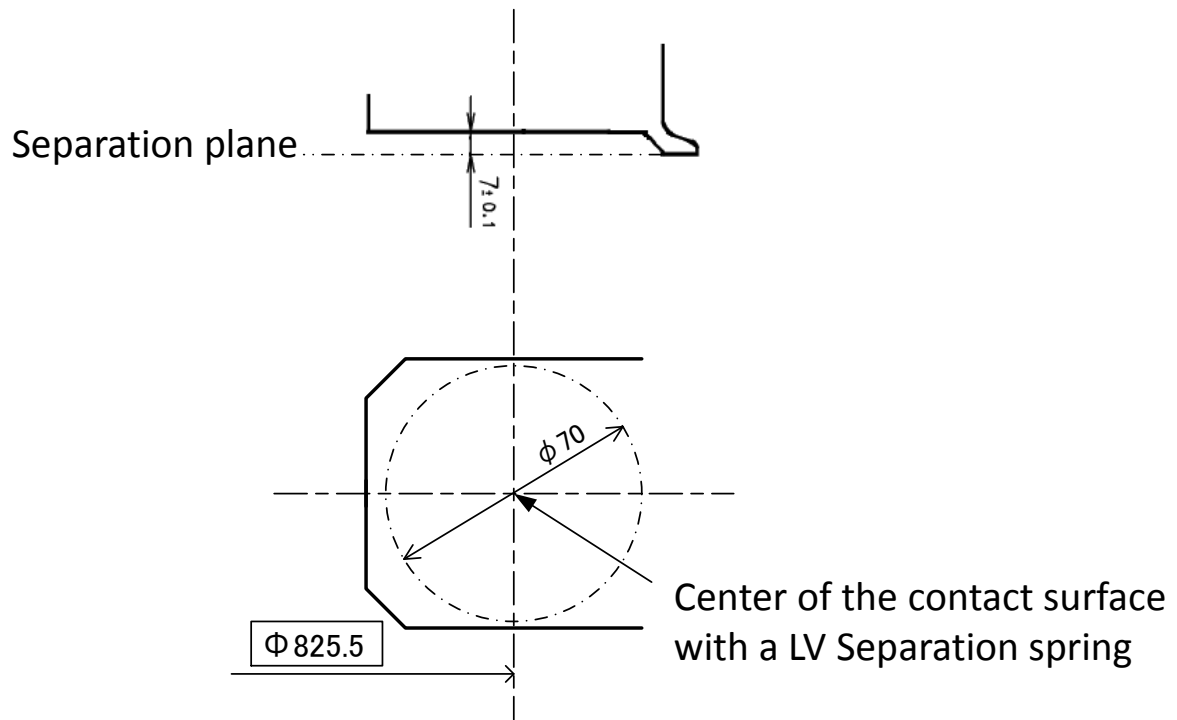

Figure A3-4 Typical Contact Surface with LV Separation Spring

(3) Material for Mating Section

The standard material for the mating section is shown in Table A3-2.

Table 4-2 Material for Mating Section

PL side	LV side
Aluminum alloy	Aluminum alloy

(4) Coating on Mating Section

The standard coating on the mating section is shown in Table 4-3.

Table 4-3 Coating on Mating Section

PL side	LV side
Chemical Conversion Coating MIL-C-5541 class 3	Chemical Conversion Coating MIL-C-5541 class 3

(5) Separation Connector

The side view of a separation connector after mating are shown in Figure A3-5.

The layout of PL's separation connectors on the Y_B - Z_B plane are shown in Figure A3-6.

Insert normal and clocking (keying) positions of PL's separation connectors are also shown in Figure A3-6. If any change is needed, contact your Program Director.

The specifications of separation connectors are described in the next chapter A4.

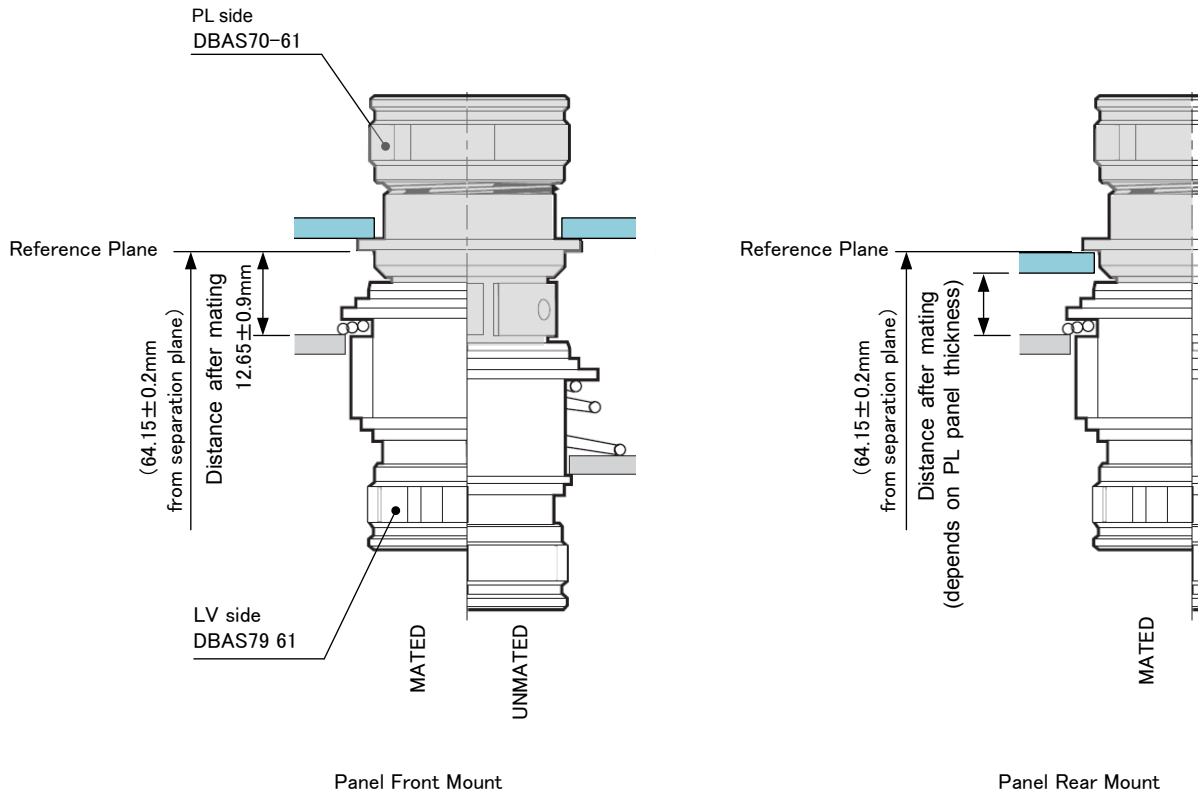

Figure A3-5 Side View of Mated Separation Connector

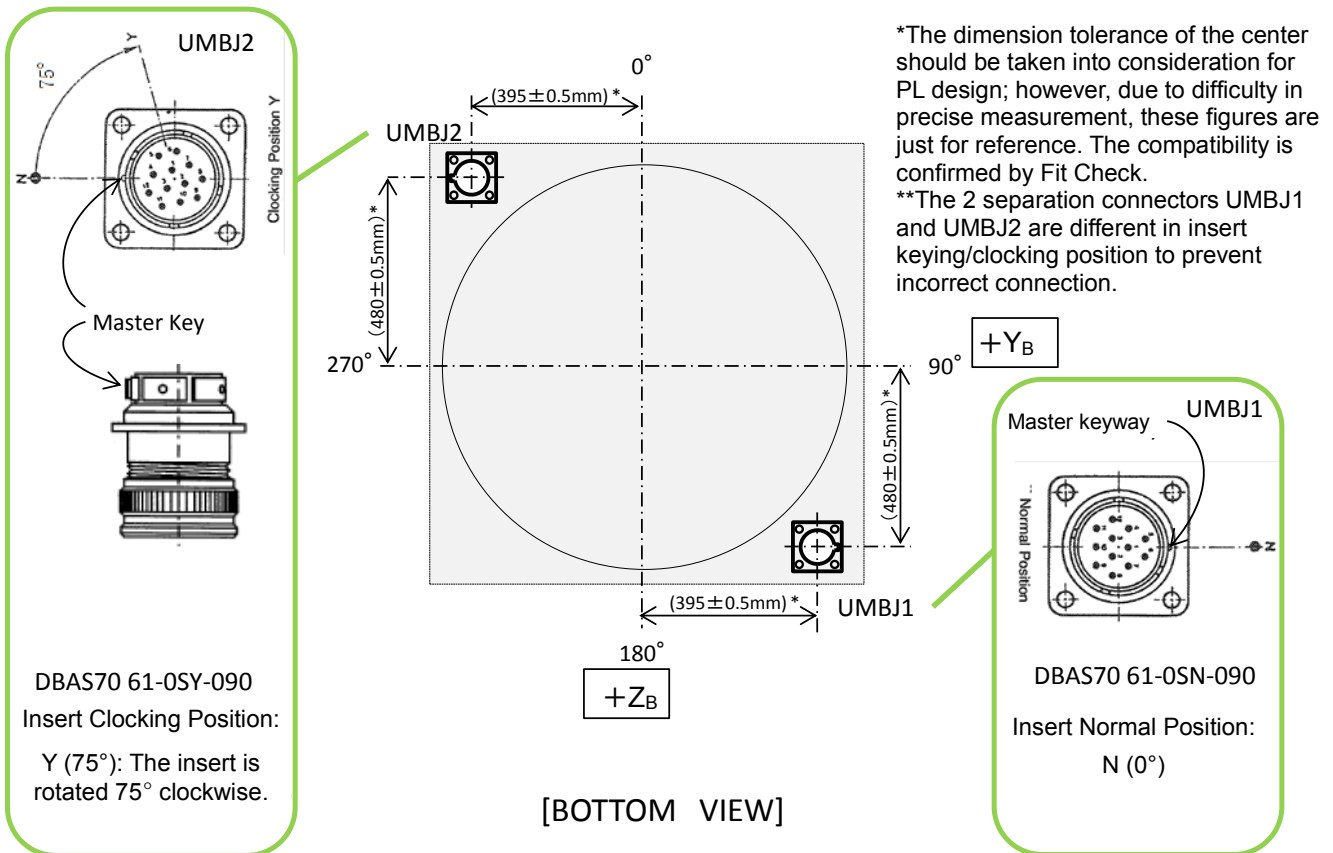

Figure A3-6 Layout and Insert Normal/Clocking Positions of PL's Separation Connectors

(6) Separation Switch (Micro Switch)

Separation switches, which detect PL/LV separation status, are installed on LV side (PAF). More switches can be mounted on PL side (PL rear frame) if needed. The standard number of the switches is 2 for each side.

The standard specifications of the separation switch are shown in Table A3-4.

The position of PL separation switch (if needed) and its contact surface on LV side are shown in Figure A3-7.

The position of LV separation switch and its contact surface on PL side are shown in Figure A3-8.

Table A3-4 Standard Specifications of Separation Switch

Parts No.		Force (minimum)	Force (maximum)
M8805/80-01	after separation	17.8 [N] (stroke 0 [mm])	53.3 [N] (stroke 0 [mm])
	before separation	35.1 [N] (stroke 2 [mm])	103.6 [N] (stroke 4 [mm])

※The "stroke" is the distance between the top of switch in pressed position and that in unpressed position. The distance is 0 [mm] when the switch is unpressed.

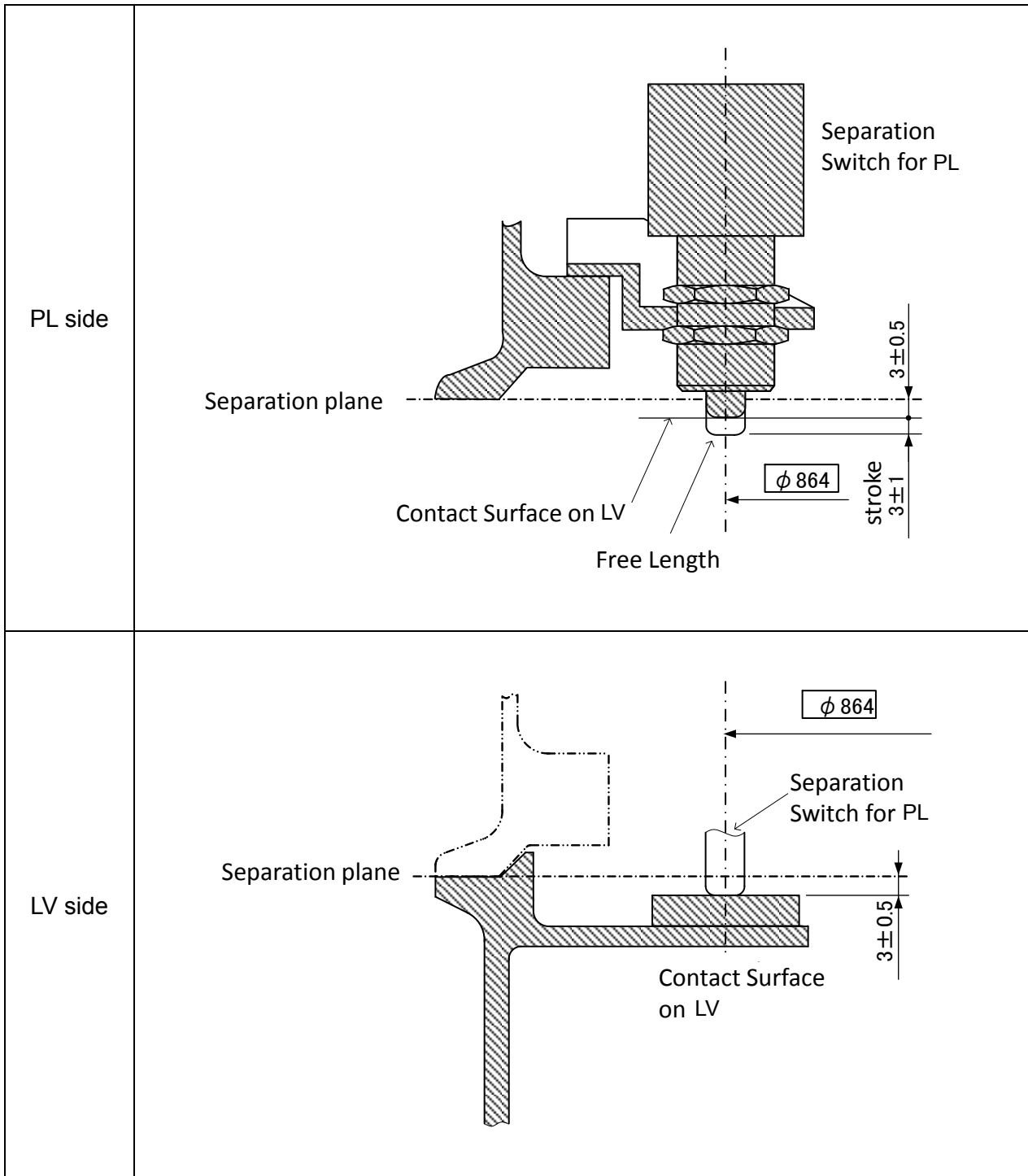

Figure A3-7 Position of Separation Switch on PL side and Contact Surface on LV

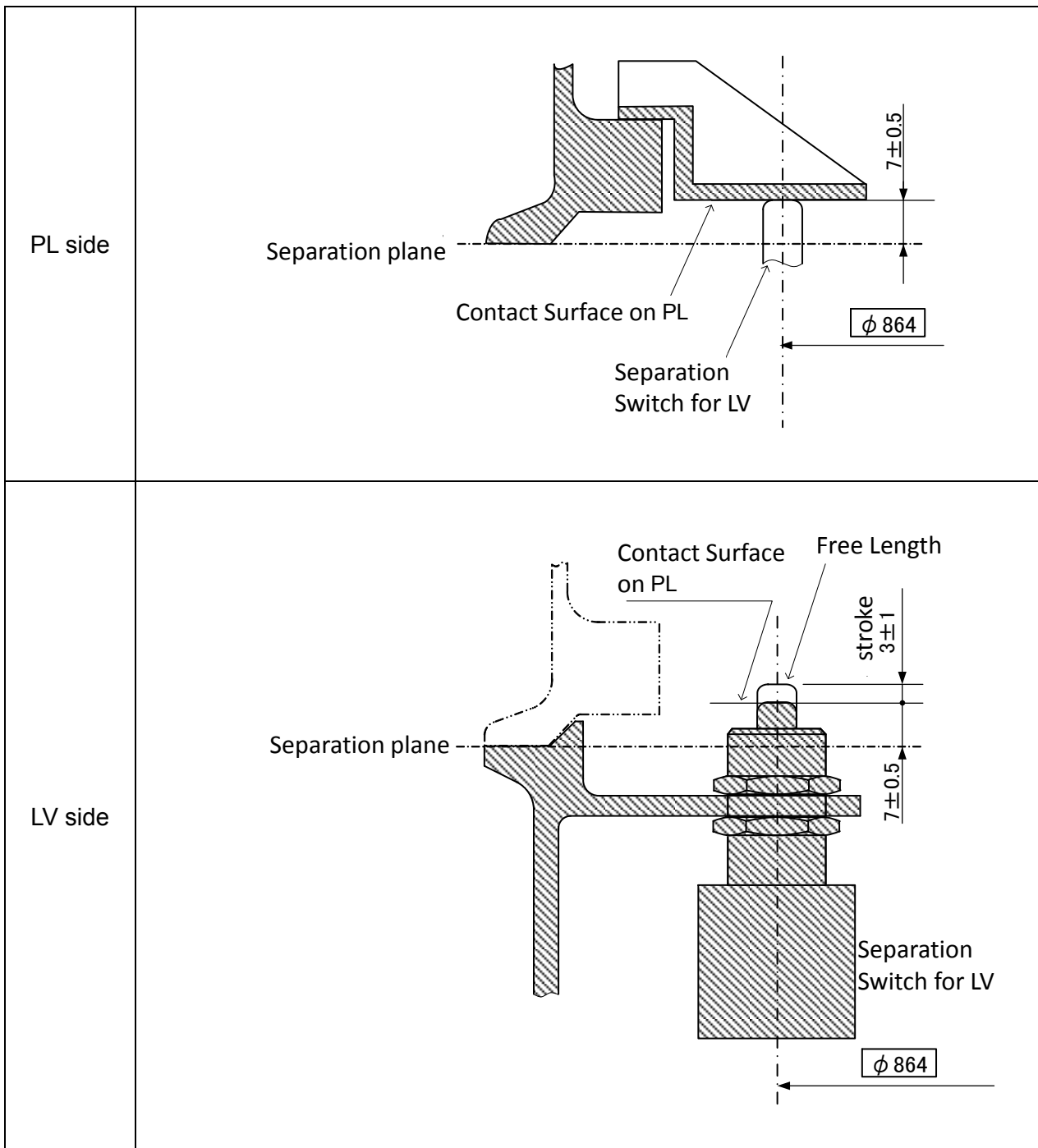

Figure A3-8 Position of Separation Switch on LV side and Contact Surface on PL

(7) Separation Spring

Table A3-5 shows the number of separation springs. The number will be decided by LSP according to the mass of PL and the separation speed that varies for the LV configuration. The locations of separation springs are shown in Figure A3-2.

If Customer requires any change in the number and location, contact your Program Director.

The load applied to PL's rear flame by a separation spring during PL/LV mating is specified in Section (1).

Table A3-5 Number of Separation Springs

LV Configuration	Nominal Separation Speed	Number of Separation Spring
Optional with PBS	0.5 m/s	4
Basic without PBS	2.0 m/s	4, 8 or 12 (Depends on the PL mass)

A4. Electrical Interface

A4. 1 Separation Connector

The standard characteristics of the separation connector are shown below.

The two separation connectors (UMB1 & UMB2) are different in keying/clocking to prevent incorrect connection.

(1) Part Number

The part numbers of the separation connectors are shown in Table A4-1.

Table A4-1 Part numbers of Separation Connectors

	Connector Identification	Part No.	Manufacturer
PL side 1	UMBJ1	DBAS70 61-0SN-090	DEUTSCH
PL side 2	UMBJ2	DBAS70 61-0SY-090	DEUTSCH
LV side 1	UMBP1	DBAS79 61-0PN	DEUTSCH
LV side 2	UMBP2	DBAS79 61-0PY	DEUTSCH

(2) Location

See Figure A3-2.

(3) Shield Requirements

Shield requirements for the back shells and I/F harnesses are shown below.

Table A4-2 Shield Requirements

	Shield Requirements
Back shell	N/A
I/F harnesses	dependent on signals

(4) Procurement

PL side connectors are provided by Customer, and LV side ones by LSP.

(5) Pin Assignment

The pin assignments of the separation connectors are determined for Customer. Table A4-3 and Table A4-4 show the typical pin assignments.

Table A4-3 Typical Pin Assignment of UMBP1

UMB P1 (Power)	
Pin No.	Signal Name
24	Power 1 (1)
58	Power 1 RTN (1)
44	Power 1 (2)
35	Power 1 RTN (2)
3	Power 1 (3)
57	Power 1 RTN (3)
11	Power 1 (4)
34	Power 1 RTN (4)
25	Power 1 (5)
17	Power 1 RTN (5)
45	Power 1 (6)
6	Power 1 RTN (6)
4	Power 1 (7)
55	Power 1 RTN (7)
12	Power 1 (8)
56	Power 1 RTN (8)
26	Power 1 (9)
33	Power 1 RTN (9)
46	Power 1 (10)
16	Power 1 RTN (10)
22	Power 2 (1)
60	Power 2 RTN (1)
42	Power 2 (2)
37	Power 2 RTN (2)
9	Power 2 (3)
59	Power 2 RTN (3)
23	Power 2 (4)
36	Power 2 RTN (4)
43	Power 2 (5)
19	Power 2 RTN (5)
10	Power 2 (6)
18	Power 2 RTN (6)
40	Power 2 (7)
61	Power 2 RTN (7)
41	Power 2 (8)
38	Power 2 RTN (8)
51	Separation Status
52	Separation Status RTN
47	SHIELD
54	SHIELD
48	Power 3 (Low Power)
53	Power 3 (Low Power) RTN

Table A4-4 Typical Pin Assignment of UMBP2

UMB2 (signal)				
Pin No.	Signal Name		Pin No.	Signal Name
2	Signal 1		49	Signal 19
8	Signal 1 RTN		50	Signal 19 RTN
7	Signal 2		5	Signal 20
19	Signal 2 RTN		6	Signal 20 RTN
18	Signal 3		13	Signal 21
36	Signal 3 RTN		14	Signal 21 RTN
17	Signal 4		22	Signal 22
35	Signal 4 RTN		46	Signal 22 RTN
47	Signal 5		9	Signal 23
48	Signal 5 RTN		10	Signal 23 RTN
57	SHIELD		11	Signal 24
58	SHIELD		12	Signal 24 RTN
3	Signal 6		30	Signal 25
4	Signal 6 RTN		56	Signal 25 RTN
25	Signal 7		45	SHIELD
26	Signal 7 RTN			
27	Signal 8			
28	Signal 8 RTN			
15	Signal 9			
31	Signal 9 RTN			
16	Signal 10			
32	Signal 10 RTN			
20	Signal 11			
39	Signal 11 RTN			
21	Signal 12			
40	Signal 12 RTN			
33	Signal 13			
34	Signal 13 RTN			
41	Signal 14			
42	Signal 14 RTN			
37	Signal 15			
38	Signal 15 RTN			
60	Signal 16			
61	Signal 16 RTN			
55	SHIELD			
23	Signal 17			
24	Signal 17 RTN			
43	Signal 18			
44	Signal 18 RTN			
51	Separation Detection			
52	Separation Detection RTN			

A4. 2 Separation Switch

For electrical interfaces of separation switches, refer to the specification sheet of M8805/80-01.