

PULSE 6X

HAND HELD PULSE DETECTOR

OPERATION MANUAL



P1250-1/P4/OPER MAN-NEW

J. W. FISHERS MFG INC
1953 COUNTY STREET
E. TAUNTON, MA 02718

INTRODUCTION

The Pulse 6X is one of the finest hand-held metal detectors made today. They are used by professional organizations world-wide and are in use today by US and foreign governments. The Pulse 6X has the added benefit of being up-gradable to the top performing Pulse 8X at anytime in the future.

HOW PULSE DETECTORS WORK

Pulse detectors operate by transmitting a continuous stream of high energy magnetic pulses (one hundred per second), from the coil. After each pulse is transmitted, the unit then "listens" using the coil as the receiving antenna.

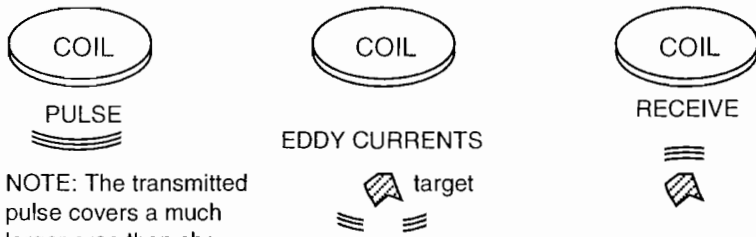

NOTE: The transmitted pulse covers a much larger area than shown above.

Figure 1

When a transmitted pulse hits a metal object, a magnetic field is induced in the object. This causes eddy currents to flow in the metal, which in turn generates a second magnetic field. This field is picked up by the coil, amplified, and then displayed by the meter and heard in the speaker/earphone.

Almost all metals are detectable by pulse induction. Stainless steel bolts are not, but stainless steel props are (high iron content). The shape of the metal can also influence its detectability. Almost any shape of target is detectable except small loops of metal such as those used in a necklace. Larger loops, such as rings are detectable. Some rings are made of metal alloys that are not detectable.

DETECTION AREA

The detection area for our pulse detectors is bowl shaped and much larger than the coil diameter.



The above illustration represents the detection area for a penny with a 7 1/2" coil. A larger object would have a larger detection area.

Different size coils will effect the detection distance. The larger the coil the deeper the ground penetration for larger objects; but the larger coils will not detect small (coins, rings) targets as well as small coils.

If you purchased the underwater connector option you can easily change coils in the field.

PULSE 6X SENSITIVITY

- SMALL RING 2 1/2 IN. (6 1/2 cm)
- NICKEL 3 IN. (7 1/2 cm)
- PENNY 4 1/2 IN. (11 cm)
- QUARTER 5 IN. (13 cm)
- 2"x2"x1/8" ALUM 7 IN. (18 cm)
- 4"x4"x1/8" ALUM 9 IN. (23 cm)
- 1 GALLON CAN 22 IN. (55 cm)
- LARGER TARGETS TO A MAXIMUM 3 1/2 FT. (105 cm)

ASSEMBLY FOR UNDERWATER USE

- Attach the electronics housing to the underwater PVC handle assembly using the (2) 10-32x1 1/4" thumbscrews with washers.

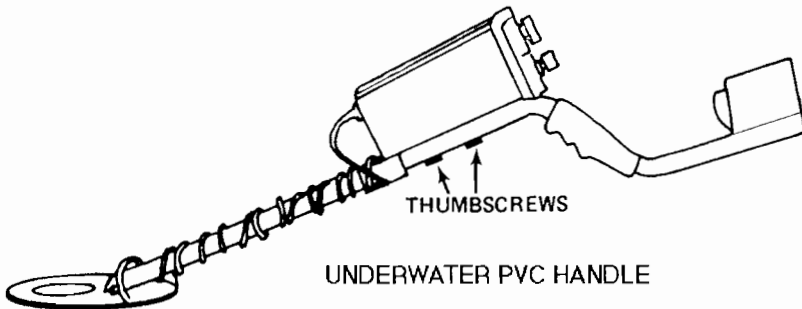

- Neatly wind the coil wire around the Coil Shaft.
- Attach the forked end of Coil Shaft to the Coil using the 3/8"-16 black nylon bolt, washers and wing nut.

NOTE: If you purchased the optional "underwater connector on coil wire" (it is black hard plastic), the coil wire can be removed from the case by turning the knurled ring, on the connector, counterclockwise 1/2 turn and pulling the connector straight out. Be sure you do not lose the O-ring which is inside the electronics housing side of the connector. The O-ring size is 3/8" ID x 1/16".

The PULSE 6X is now ready to be operated in the standard underwater configuration.

OPTIONAL UNDERWATER SETUP

Remove the Electronics Housing from the Arm Rest Handle by removing the (2) 10-32x1 1/4" thumb screws.

The Electronics Housing can now be worn on the waist by sliding the belt through the (2) belt holders on the underside of the housing.

ASSEMBLY FOR LAND USE

Your detector comes with an aluminum land handle that was designed as a result of extensive customer feedback. The new handle is constructed of heavy-gauge aluminum with adjustable coil shaft and arm support. Both shafts adjust quickly with the push of a button. O-rings added to the arm support shaft eliminate play giving the handle a solid feel. The electronics housing can be worn around the waist/chest or it can be mounted on the handleshaft.

- Attach the coil to the forked end of the aluminum land handle with the 3/8 x 1 1/2" black nylon bolt and wing nut.

For belt mount:

- Slide the yellow belt through the belt holders on the underside of the electronics housing. Wear the belt around the waist or chest.

For pole mount:

- Attach electronic housing to pole handle using 10-32 x 1 1/2" thumb screws.

ALUMINUM LAND HANDLE

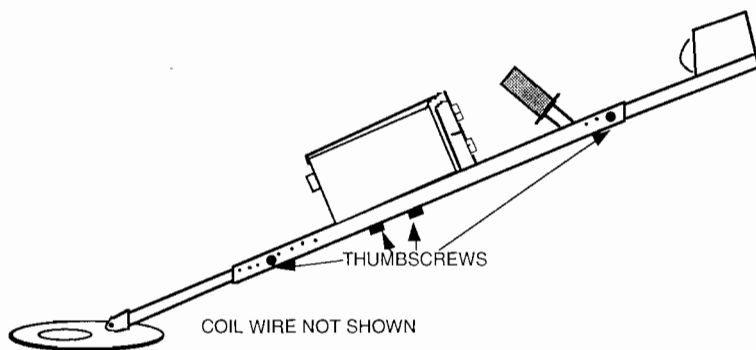

SWITCH/CONTROLS CONNECTORS

On-Off

Zero Adjust

A control knob that turns the unit on/off and adjusts the position of the needle on

the meter scale. With no metal near the coil, the zero adjust knob is turned up until the audio just starts to fire (.2), and then the knob is backed off a small amount.

"Ear" Connector

Provides the audio output to underwater or land earphones (optional). An audio signal will be heard with a meter reading of .2 and above. The frequency (tone) of the signal shifts with a change in the meter. The earphone can be attached in or out of the water. The single underwater earphone is used by sliding it under the mask strap or into the hood on or near the ear. The earphone can be connected to the detector in or out of water. An optional dual underwater headset is also available.

The optional stereo land headset should be kept out of water. However, the connector is waterproof and can be submerged with the detector when wading in the water. The volume of the land headset can be adjusted by a control knob on the outside of each earmuff.

Battery Charger

The connector is located on the back of the case. The Zero Adjust switch must be in the OFF position for charging to take place. It is not necessary to cover this connector when diving.

Charge LED

Indicates that the batteries are being charged. Full charge will occur in 12 to 14 hours. The light does not go out when batteries are charged.

Batt Low LED

Indicates that the batteries are low and need recharging. When light first starts to flicker, operating time left is approximately 30 minutes.

OPERATION

1. After the unit has been assembled, for underwater or land use, take it outside to familiarize yourself with its operation. Position the unit so that the coil is away from all metals.
2. Turn the unit on by turning the Zero Adjust knob clockwise. Use the Zero Adjust knob to tune the needle just below .2 (audio stops) on the meter scale. You are ready to start detecting.
3. Locate a "clean area" of ground (no readings) and place different sizes of metal objects on the ground and practice detecting and pinpointing them.
4. Due to the high sensitivity of the PULSE 6X, pinpointing the target when it is close to the surface can be difficult. When this occurs, lift the coil off the ground as high as possible while still detecting the target. Due to the cone shaped detection pattern, the greatest reading will occur when the target is directly below the center of the coil.

NOTE:

If you get too close to a metal object, it causes the meter to peg up and it will stay up for a few seconds even after you pass over it.

When this happens, lift the coil up (increase the distance to the target) and make another pass to pinpoint target.

BATTERY CHARGERS

The Chargers (120vac or 12vdc) connect to the connector on the back of the PULSE 6X case. Charge current will be 120-130 mA and will require 12-14 hours to completely recharge dead batteries. The charge LED on the faceplate will illuminate while the charging is taking place (when charging from a 12v battery, the light may dim or go out as the batteries near full charge). Do not leave the charger continuously charging the batteries (for many days), this can shorten the battery life. Charged batteries will power the detector for 9-10 hours. The batteries should be completely discharged at least once a year before fully charging; this gets rid of any "battery memory".

CHARGER OPERATING PROCEDURES

- Select charger to be used 120vac or 12vdc
- Wipe off charger connection on bottom of PULSE 6X case.
- Connect output of charger to connector on bottom of case, do not over tighten, just snug will do.
- Turn Zero Adjust switch on detector to OFF.
- Connect input power to charger
Note: If using 12V battery as input, connect red clip to position (+) on battery.
- Charge LED on faceplate will be illuminated while charging is taking place.
- When fully charged, it will provide 9-10 hours of continuous use, and requires 12-14 hours to fully recharge (it cannot be overcharged).
- DO NOT USE ANY CHARGER OTHER THAN THE ONE PROVIDED.

OPTIONAL SPARE BATTERY PACK

The spare battery pack is identical to the battery pack contained in the PULSE 6X case.

Charging Spare Battery Pack

If you purchased a spare battery pack it must be charged (12-14 hrs.) by putting it into the case (see below).

Changing Batteries

- Remove the six 6-32x5/8" stainless screws from the top of the case.
- Lift the electronics straight up.
- Slowly tilt the case allowing the battery pack to slide out.
- Unplug the battery cable from the board and plug in the new battery (OK to reverse the plug around).
- Clean the o-ring and o-ring seat on the top of the case.
- Install the foam sheet around the battery and position under the electronics.
- Place the o-ring around the small faceplate (sm faceplate is inside the large faceplate). Carefully insert the battery and electronics into the case.
- Use several pieces of thin cardboard inserted between faceplate and case, and push the o-ring into place while applying pressure on top of the faceplate.
- Insert the screws and snug up. DO NOT OVER TIGHTEN.

Optional Cable and Connector and Coils

An underwater connector on coil wire is available. It allows the coil to be disconnected from the electronics housing. This enables field changing of different size coils. The available coils are: 7 1/2", 10" 16", 18" with 100' cable, 8" x 48" oval with skids, and hand held 1" probe (for pushing into sand/mud). When removing or installing new coils be sure the o-ring is in place (on housing half of connector). The o-ring size is 3/8" ID x 1/16" W.

MAINTENANCE

Your Pulse 6X was designed to be maintenance free. It is constructed of corrosive resistant materials. However, as with most diving equipment, it is recommended that it be rinsed in fresh water after use and stored in a cool dry place.

LIMITED WARRANTY

Your unit underwent constant inspection during assembly to insure many years of trouble free performance. The PULSE 6X is warranted for TWO FULL YEARS from the date of purchase. During this period, your unit will be repaired free of charge should a failure occur due to materials or workmanship. The Warranty does not cover broken or cut cables, broken shafts or coils, or damage due to droppage or general misuse.

Should service be required, write/phone us explaining the nature of the problem, and we will supply shipping instructions. All repairs are made at our factory. Repairs by unauthorized persons may void the Warranty.

RETURNING DETECTOR FOR REPAIR

If your detector should need service, you can write, phone (508) 822-7330, or fax (508) 880-8949 the factory for instructions. We do not require authorization for the return for equipment. If you have a problem with your detector and would like to have it checked out at the factory, simply pack the detector well and return it with a brief note describing the problem. Be sure to include your return address and telephone number on the note.

When returning equipment from outside of the US, contact the factory for specific instructions before returning the detector.